

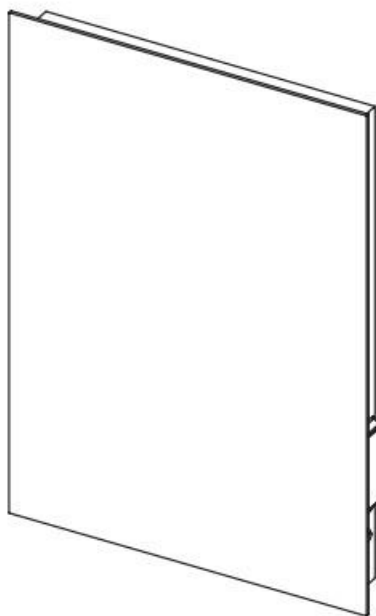

Thank you for choosing Better Bathrooms.
Please read this manual before installing your product
and keep for future reference.

better 
bathrooms

WALL MOUNTED FRAMELESS BATTERY MIRROR



ELIOBP500

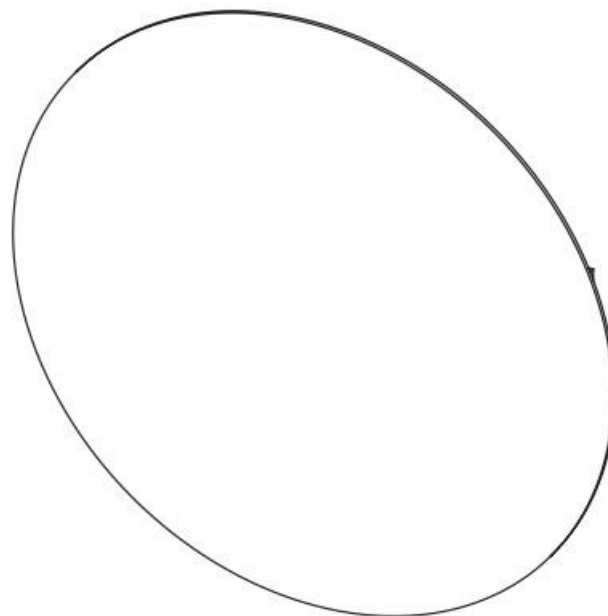

ELIOBP600 ELIOBP800

- BATTERY POWERED
- IP44 INGRESS PROTECTION
- SINGLE PERSON ASSEMBLY

CONGRATULATIONS ON YOUR PURCHASE

Our aim at Better Bathrooms is to bring you extraordinary bathroom products for less.

If you're after a modern, traditional, or totally unique bathroom style, we have the fittings and fixtures to bring your ideas to life so you can fall in love with your space every day.

We hope your new product goes above and beyond your expectations. However, should any problems occur, please:

- Log in to your account and contact our customer services team via your self-service portal – betterbathrooms.com/CustomerAccount/Login
- Contact us via betterbathrooms.com/contact/contact-us

CONTENTS

SAFETY	3
PARTS SUPPLIED	4
TOOLS REQUIRED	4
DIMENSIONS	5
INSTALLATION	6
OPERATION	8
CHARGING THE BATTERY	8
CLEANING AND MAINTENANCE	9
TECHNICAL SPECIFICATIONS	9

SAFETY





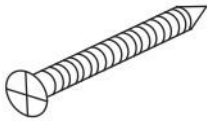
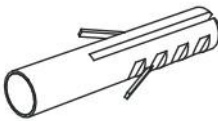
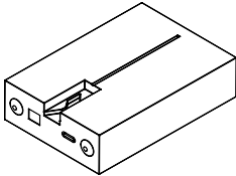
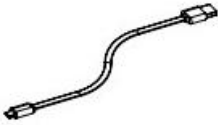

- This is for domestic, indoor use only.
- If there is a “Minimum Distance” Label, please do not allow Flammable Materials to rest within that distance from the unit.
- This product may contain delicate parts – be careful during handling and maintenance to avoid breakage.
- Any modification to the fitting will invalidate the warranty and may render the product unsafe.
- This product is IP44 rated, and no part of the installation is allowed to be within bathroom Zones 0 or 1. Installation is permitted within Zone 2.
- Before commencing installation, ensure that there are no pipes or wires located behind the wall that may be damaged during drilling.
- Ensure that the hanging location has been decided upon and marked clearly to avoid unwanted damage to the wall due to incorrect positioning.
- Check that the mirror is not damaged prior to installation.
- Once installed, a bead of silicone can be applied between the mirror and the wall along the top and sides of the unit. Do not seal the bottom edge, as this may trap water behind the mirror and cause damage.
- Take care of unpacking, and do not use a sharp blade to open it, as this may damage the mirror and void your warranty.
- The light source of this luminaire should be replaced by an electrician or a similarly qualified person.
- Use only the specified UE2600001 (10.95V 5000mAh) lithium rechargeable battery. Do not substitute with other batteries.
- Do not expose batteries or the product to excessive heat (e.g. direct sunlight or near radiators).
- Do not disassemble or dispose of batteries in a fire.
- Ensure battery compartment is fully closed before use.
- Remove the battery if the product will not be used for a long time.
- Keep the battery out of reach of children.
- Do not short-circuit the battery terminals.
- Dispose of used batteries according to local regulations.

PARTS SUPPLIED

	
M4 SCREWS (x2)	WALL PLUGS (x2)
	
BATTERY (x1)	USB-C CABLE (x1)

PLEASE NOTE: It is the installer's responsibility to ensure that the fittings are suitable for the type of wall. The parts provided are only suitable for masonry walls. Alternative fixings may be required for other wall types and are not included. If unsure, professional advice should be sought.

TOOLS REQUIRED

	
8mm DRILL BIT	ELECTRIC DRILL
	
PENCIL	SCREWDRIVER (Philips No 2)
	
TAPE MEASURE	SPIRIT LEVEL

DIMENSIONS

NOTE: All diagrams are for illustrative purposes. All dimensions are in mm.

ELIOBP500

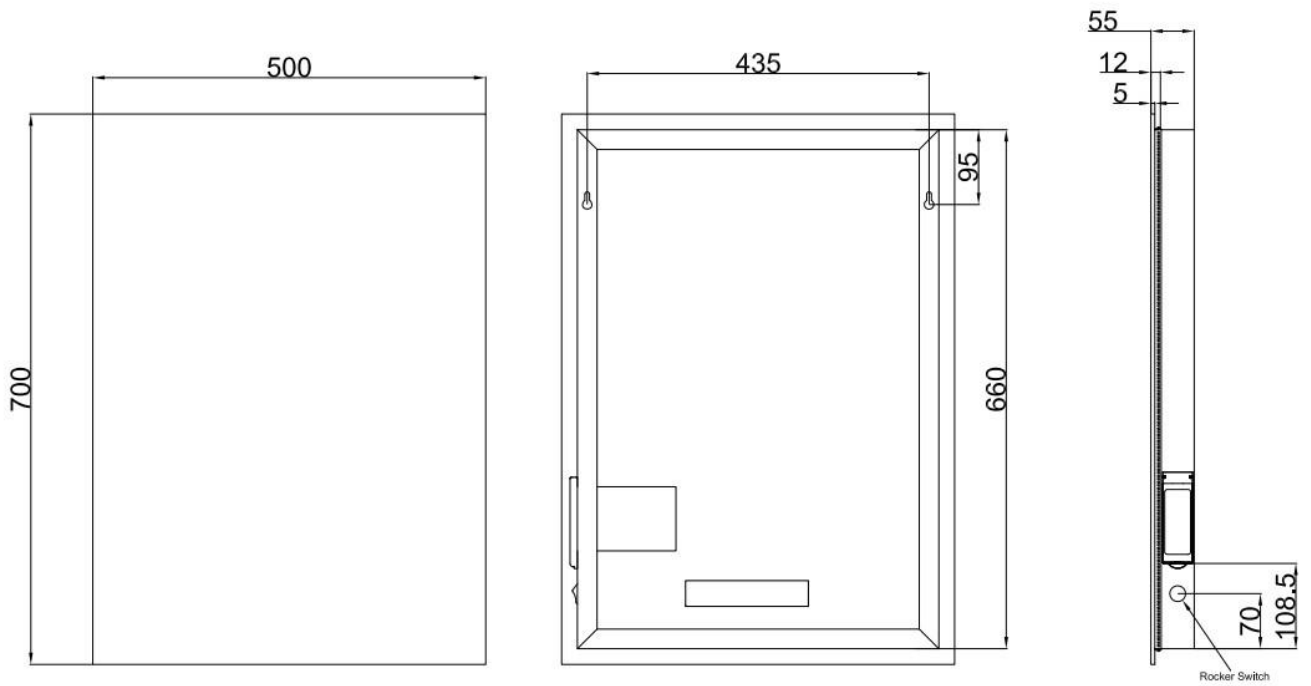

ELIOBP600

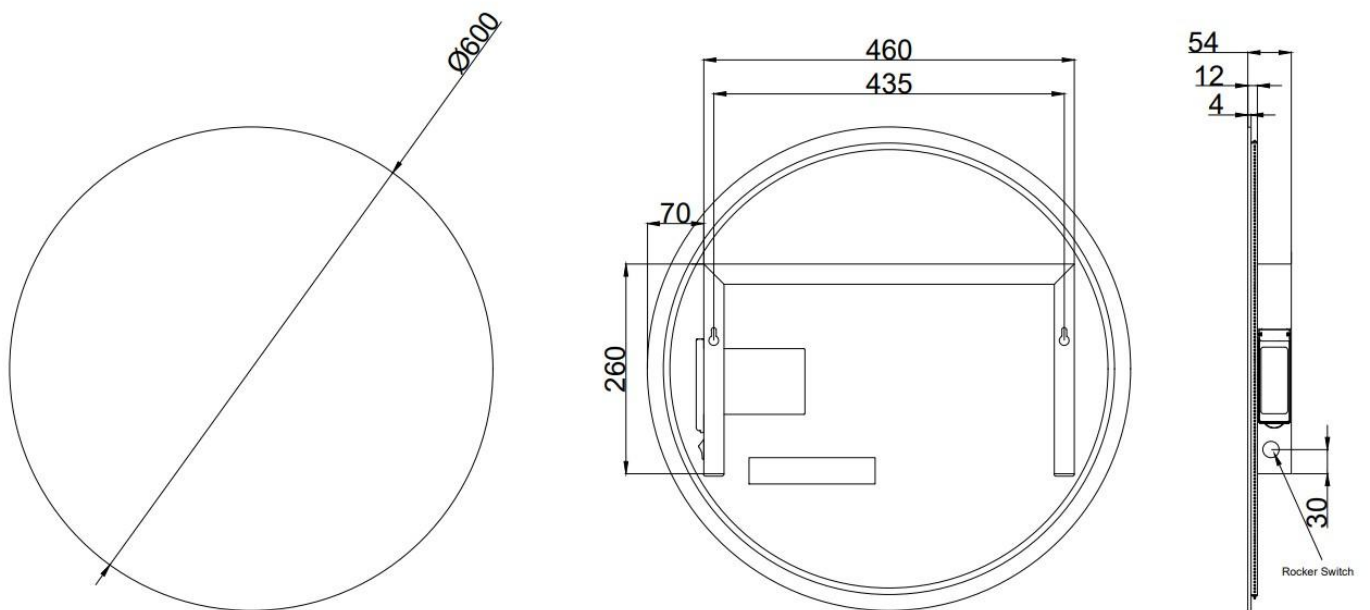

ELIOBP800

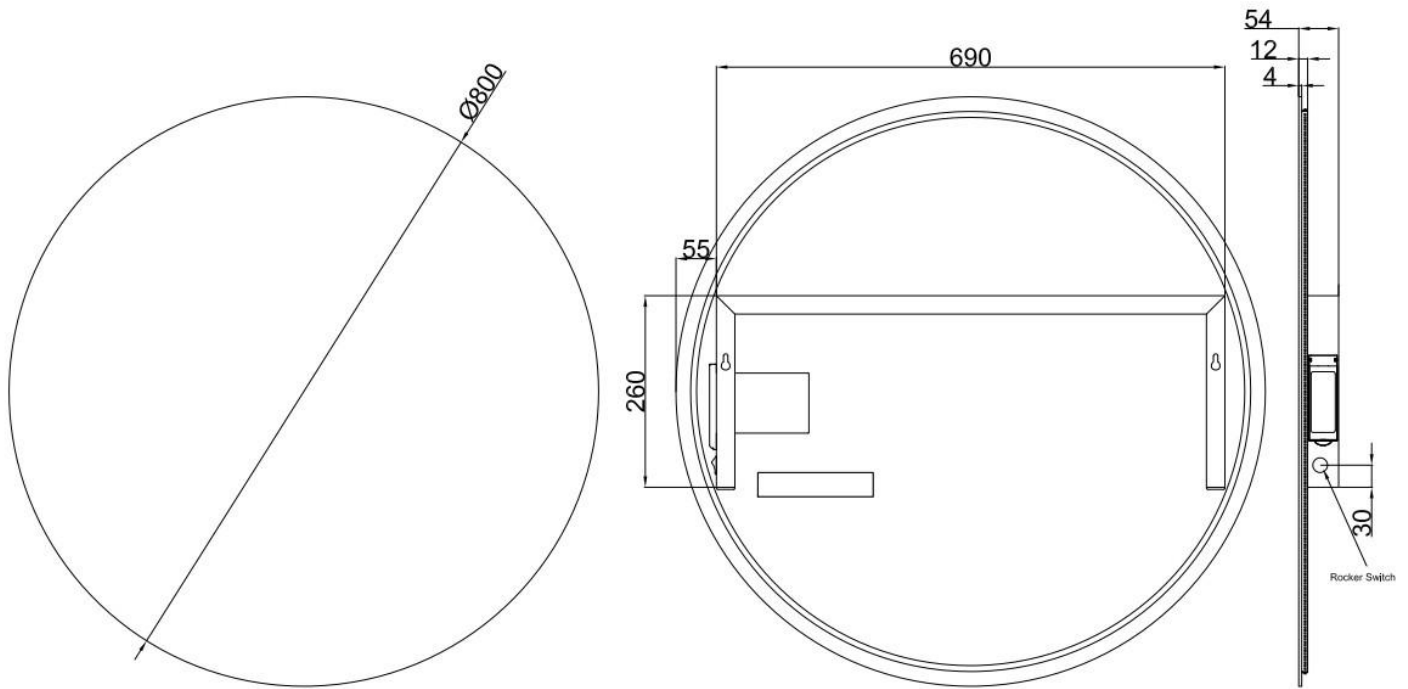

Dimensions Tolerance

Dimension Size	Tolerance Value
Up to 120 mm (4.72 in)	±1.27 mm (±0.05 in)
Over 120 mm (4.72 in)	±2.54 mm (±0.1 in)
Angles	±1°

INSTALLATION

IMPORTANT: Before commencing installation, ensure that there are no pipes or wires located behind the wall that you will be drilling into and ensure that the item is functional with the supplied battery.

- Ensure that the hanging location has been decided upon and marked clearly to avoid unwanted damage to the wall due to incorrect positioning.
- Check that the mirror is not damaged prior to installation.
- Take care of unpacking, and do not use a sharp blade to open it, as this may damage the mirror and void your warranty.



Step 1

Measure the distance between the fixing points on the rear of the mirror. Ensure that, once installed, the mirror will sit at your desired height.

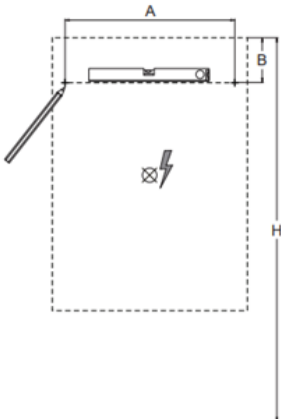
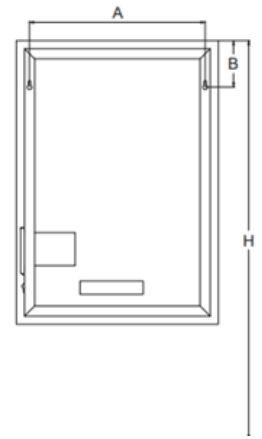

Step 2

Using a pencil, mark the fixing positions on the wall. Use a spirit level to ensure the marks are perfectly aligned.

Step 3

Drill the two fixing holes at the marked positions and insert the wall plugs. Partially screw in the M4 screws so that the heads protrude approximately 5–7 mm from the wall. This allows the mirror's keyhole slots to easily engage with the screws.

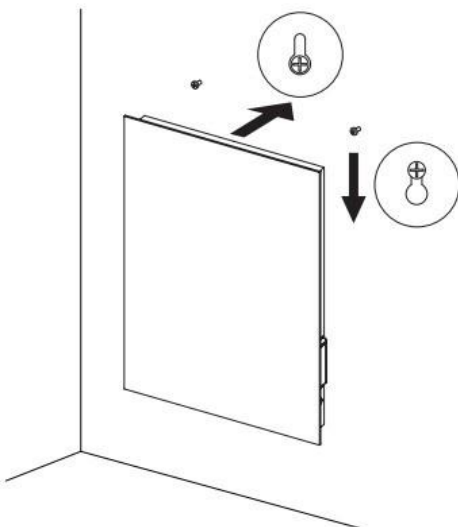
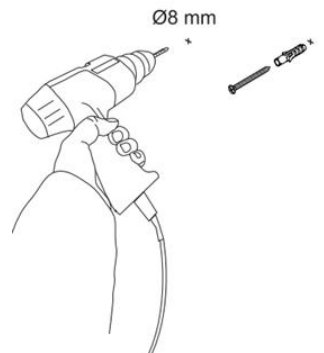

Step 4

Align the keyhole slots on the rear of the mirror with the screw heads. Carefully lower the mirror until it locks securely into place. Ensure the mirror is firmly seated and stable before use.

OPERATION

At the lower right of the mirror, a round switch lets you effortlessly turn the light on or off.

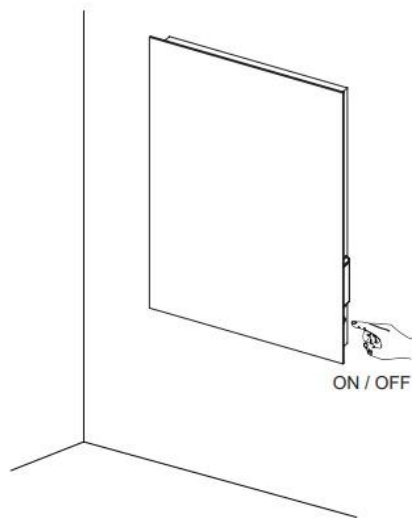

CHARGING THE BATTERY

Charging guide

Use the supplied USB-C cable to connect your device to a USB power source, such as a power bank, wall adapter, or computer, and make sure the connection is secure.

While charging, the battery's LED indicator will glow red.

When the battery is fully charged, the LED will turn blue.

Always use the supplied or a certified USB-C cable.

NOTE: Charging times may vary depending on the power source.

You may purchase a replacement battery online under model number: **UE2600001** (10.95V 5000mAh)

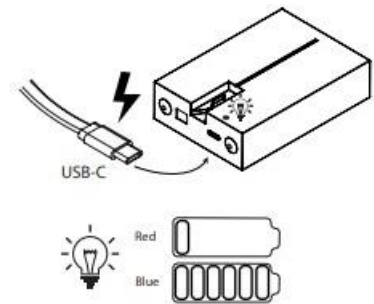

Battery Removal

1. Gently lift the battery cover.
2. Press the battery until you hear a soft click.
3. Carefully slide the battery out of the compartment.
4. The battery can be charged using the supplied USB-C cable (charger adapter not included).

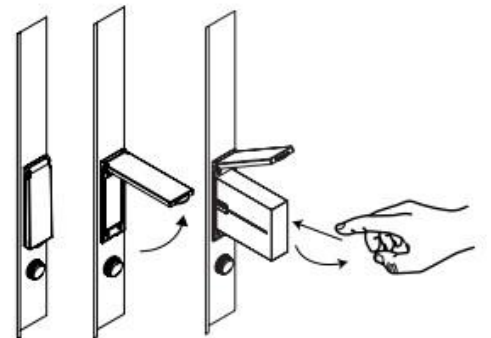

Battery Insertion

1. Lift the battery cover.
2. Align the battery contacts with the compartment contacts.
3. Slide the battery fully into place until it clicks securely.

SAFETY GUIDELINES

- Always use the supplied or manufacturer-approved battery.
- Never force the battery in the wrong orientation.
- Do not overcharge the battery.
- Keep the battery away from fire, water, and extreme temperatures.

CLEANING AND MAINTENANCE

Never use products containing bleach or abrasive cleaners, as this will have a detrimental effect on the appearance and lifespan of the product.

Use a clean microfibre cloth to clean the mirror.

TECHNICAL SPECIFICATION

Model	ELIOBP500	ELIOBP600	ELIOBP800
Dimensions (LxHxW)	500 x 700 x 55 mm	600 x 600 x 55 mm	800 x 800 x 55 mm
Net Weight (kg)	4.6	4.8	6.2
IP Rating	IP44	IP44	IP44
Rated power	3.3 W	2.7 W	3.6 W

This product contains a light source of energy efficiency class E and must only be replaced by an electrician or a similarly qualified person.

The LED strip used is a **DC 12V LED strip**.

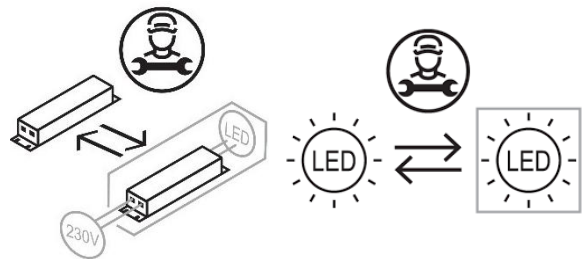

DISPOSAL



Recycling facilities are now available for all customers, where you can deposit your old electrical products. Customers will be able to take any old electrical equipment to participating sites run by their local councils. Please remember that this equipment will be further handled during the recycling process, so please be considerate when depositing your equipment. Please get in touch with the local council for details of your local household waste recycling centres.

At the time of printing the product contains no substances listed within Annex XIV of the Reach Regulations (EC) 1907/2006. In accordance with Article 59 of the same regulation, the following substances are contained within the product at permitted levels: Cadmium.

As a responsible manufacturer, we monitor the regulations to ensure continued compliance. Further information can be provided upon request.

For more information

- visit betterbathrooms.com
- email Support@Betterbathrooms.com
- call 0330 390 3062
- write to Trident Business Park, Neptune Way, Huddersfield, HD2 1UA

**better
bathrooms**

Part of the BuyItDirect Group